

## BASE FLASHING TERMINATION OPTIONS DETAIL

IB MEMBRANE STRIP. PERIMETER  
WELDED TO CLAD METAL AND BASE  
FLASHING MEMBRANE

### OPTION 1.

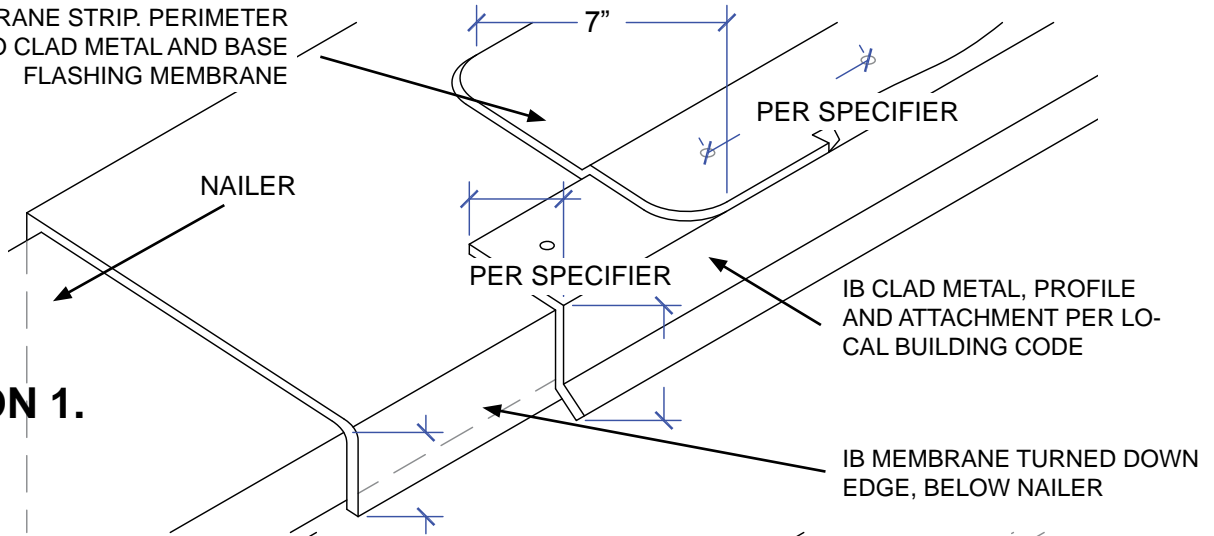

IB MEMBRANE BASE FLASHING

### OPTION 2.

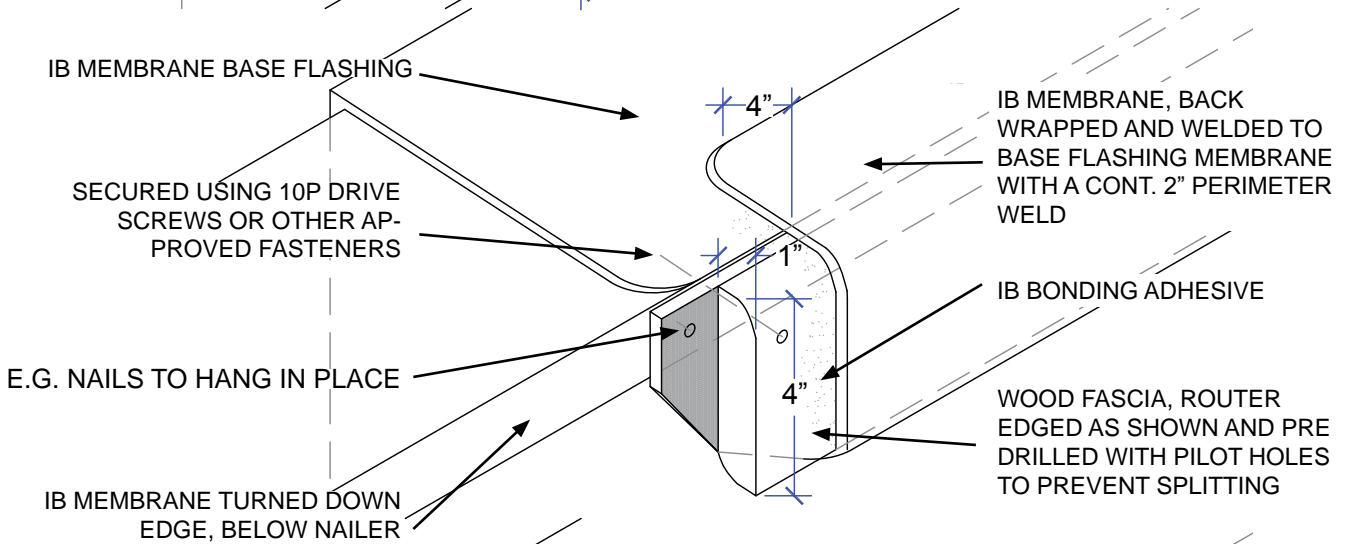

### OPTION 3.

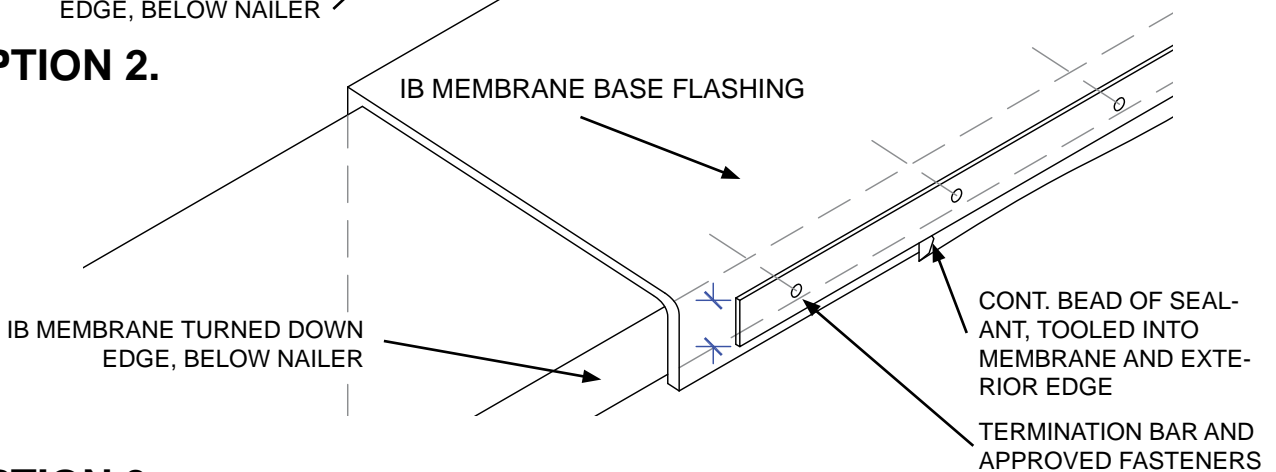

PROJECT NAME:

TITLE:

## MT-1 BASE FLASHING TERMINATION OPTIONS DETAIL

*\* Click here to link to the AutoCAD™ drawing*

SCALE: NTS

APPROVED BY:

DRAWN BY: A.SCHWAB

PLOT DATE: 11-08  
REV: AS 11-08