

LOOSE LAID HIGH WALL TERMINATION BAR ATTACHMENT

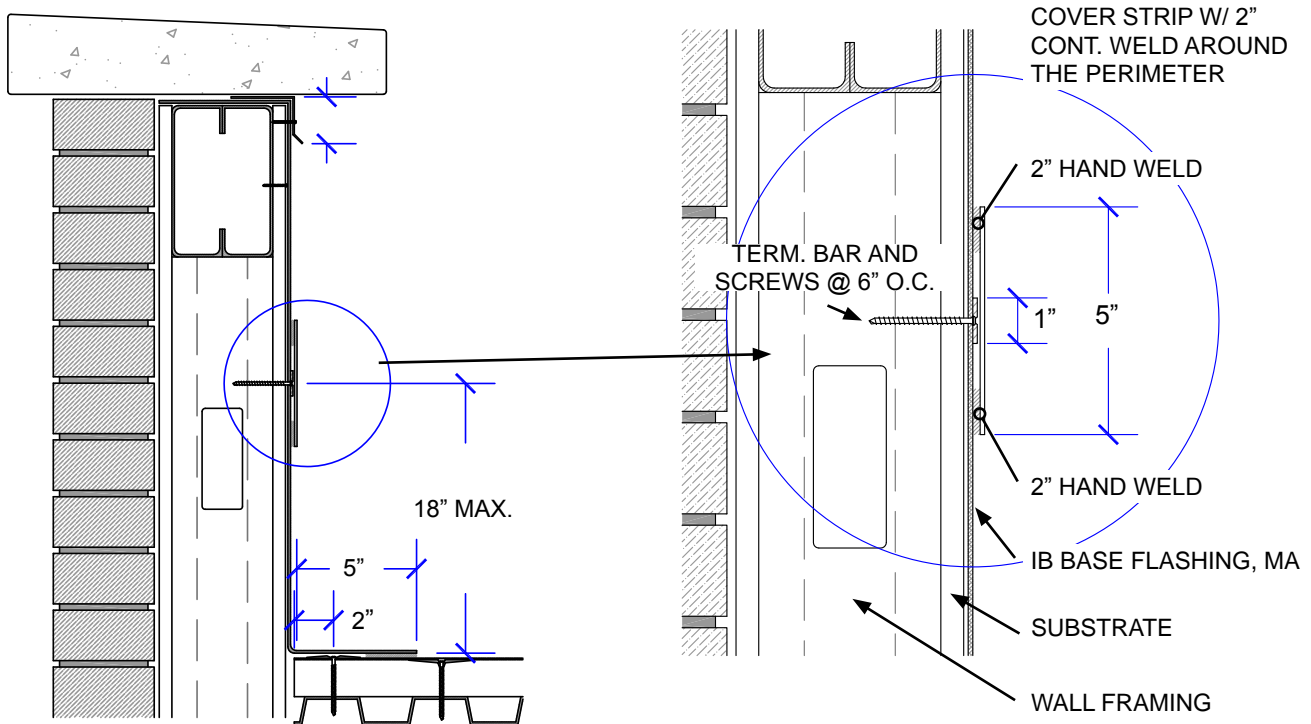

FRONT VIEW

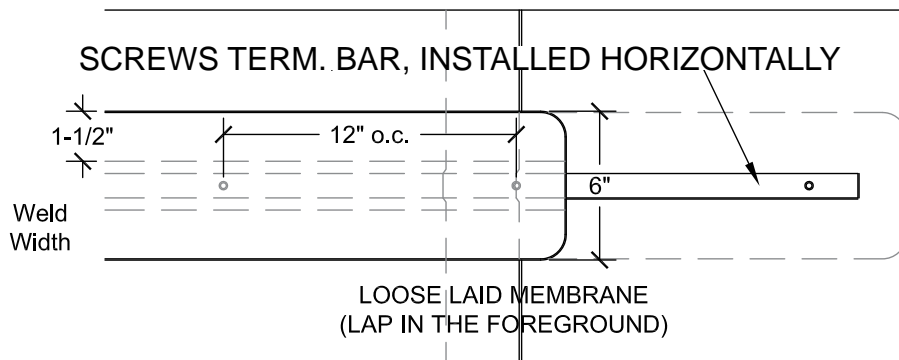

NOTES:

1. THE FOLLOWING DETAIL CAN BE USED FOR MECHANICALLY ATTACHED BASE FLASHING. FULLY ADHERED BASE FLASHING DOES NOT REQUIRE ADDITIONAL FASTENER ATTACHMENT IN THE CENTER OF THE SHEET AS SHOWN.
2. USE IB 1" ALUMINUM TERMINATION BAR WITH APPROVED SCREW FASTENERS.
3. 18" MAX. SPACING BETWEEN TERMINATION BARS UNLESS TECHNICAL VARIANCE BY IB TECHNICAL SERVICES, ALSO SEE NOTE 1.
4. MIN... 1.5" PERIMETER WELD AROUND THE COVER STRIP.

PROJECT NAME:

TITLE:

MB-12 LOOSE LAID HIGH WALL TERMINATION BAR ATTACHMENT

** Click here to link to the AutoCAD™ drawing*

SCALE: NTS

APPROVED BY:

DRAWN BY: A.SCHWAB

PLOT DATE: 11-08
REV: AS 11-08