

## SIDING TIE-IN

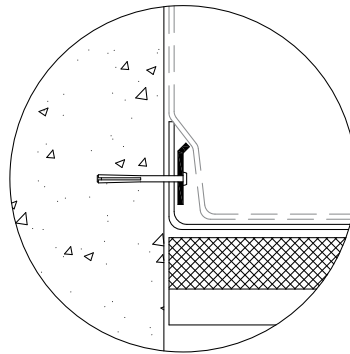
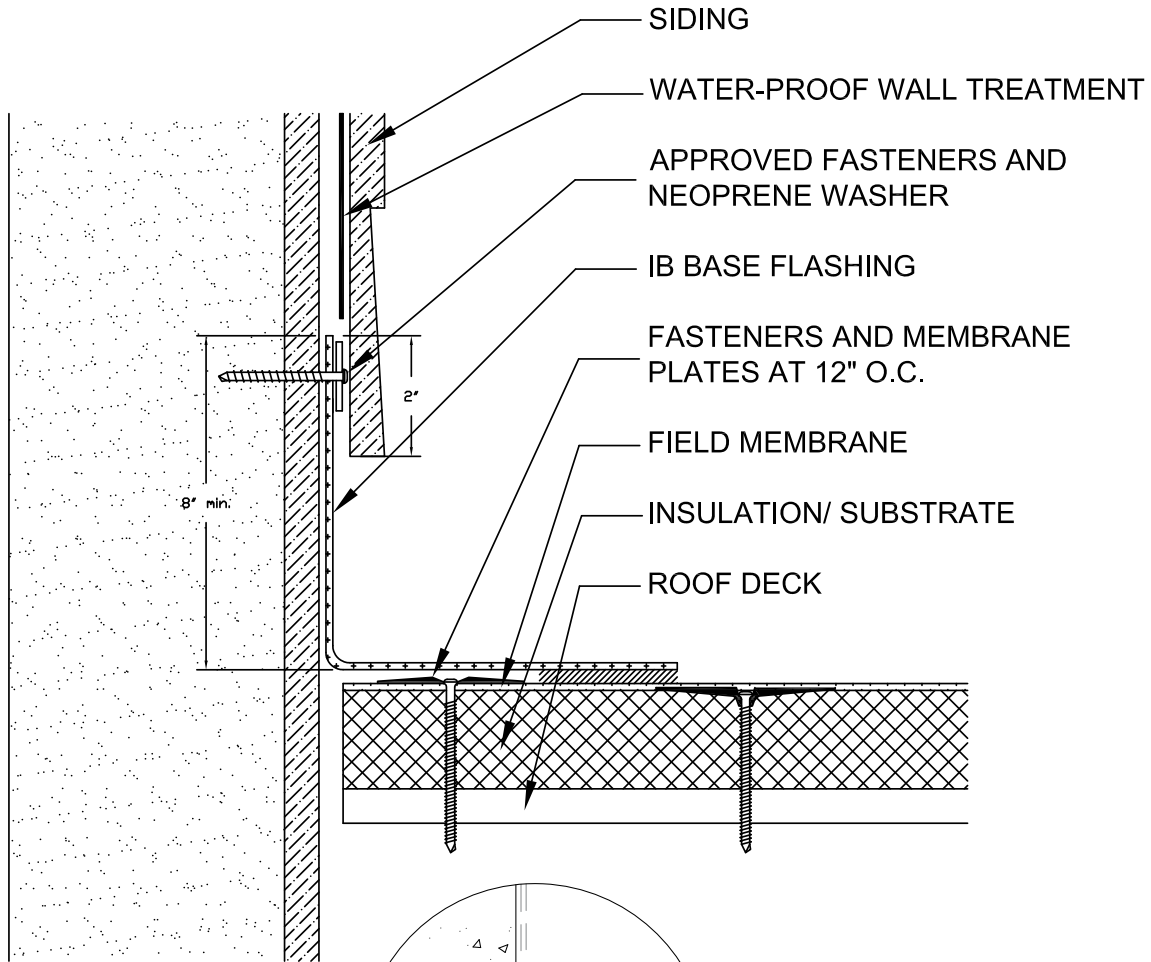

TERMINATION BAR OPTION: CAN BE USED IN LIEU OF SCREWS AND PLATES AT THE BASE OF THE WALL

**NOTES:**

1. IB VERTIBOND BONDING ADHESIVE, APPLIED AT THE NOMINAL RATE OF 2 GALS. PER SQUARE (50% TO THE BACK OF THE SHEET AND 50% TO THE SUBSTRATE) MANDATORY ON BASE FLASHING HEIGHTS OF <18" (GREATER THAN), OPTIONAL ON HEIGHTS >18" (LESS THAN).
2. RETROFIT ROOFS REQUIRE ALL EXISTING BASE FLASHING TO BE REMOVED BEFORE INSTALLING IB MEMBRANE BASE FLASHINGS.

PROJECT NAME:

TITLE:

### MB-2 SIDING TIE-IN

*\* Click here to link to the AutoCAD™ drawing*

SCALE: NTS

APPROVED BY:

DRAWN BY: A.SCHWAB

PLOT DATE: 11-08  
REV: AS 11-08